

SPECTRUM[®] Test Practice

Common Core State Standards Practice Test

Vermont Edition

Grade 8

The state of Vermont has adopted the Common Core State Standards in English Language Arts and Mathematics.

The Common Core State Standards are:

- Rigorous.
- Based on the best available evidence and research.
- Aligned with college and work expectations.
- Benchmarked to the highest educational standards from around the world.

For more information:

Common Core State Standards Initiative:

<http://www.corestandards.org/>

State of Vermont Department of Education, Curriculum and Assessment:

http://education.vermont.gov/new/html/pgm_curriculum.html

Common Core in Vermont:

<https://sites.google.com/site/commoncoreinvermont/home>

Grade 8 Common Core State Standards Practice Test**ENGLISH LANGUAGE ARTS****● Part 1: Reading Literature**

Directions: Read the story. Choose the best answers to the questions that follow.

from Anne of Green Gables***by Lucy Maud Montgomery***

“That’s Gilbert Blythe sitting right across the aisle from you, Anne. Just look at him and see if you don’t think he’s handsome.”

Anne looked accordingly. She had a good chance to do so, for the said Gilbert Blythe was absorbed in stealthily pinning the long yellow braid of Ruby Gillis, who sat in front of him, to the back of her seat. He was a tall boy, with curly brown hair, roguish hazel eyes, and a mouth twisted into a teasing smile. Presently Ruby Gillis started up to take a sum to the master; she fell back into her seat with a little shriek, believing that her hair was pulled out by the roots. Everybody looked at her and Mr. Phillips glared so sternly that Ruby began to cry. Gilbert had whisked the pin out of sight and was studying his history with the soberest face in the world; but when the commotion subsided he looked at Anne and winked with inexpressible drollery.

“I think your Gilbert Blythe IS handsome,” confided Anne to Diana, “but I think he’s very bold. It isn’t good manners to wink at a strange girl.”

But it was not until the afternoon that things really began to happen.

. . . Gilbert Blythe was trying to make Anne Shirley look at him and failing utterly, because Anne was at that moment totally oblivious not only to the very existence of Gilbert Blythe, but of every other scholar in Avonlea school itself. With her chin propped on her hands and her eyes fixed on the blue glimpse of the Lake of Shining Waters that the west window afforded, she was far away in a gorgeous dreamland hearing and seeing nothing save her own wonderful visions.

Gilbert Blythe wasn’t used to putting himself out to make a girl look at him and meeting with failure. She SHOULD look at him, that red-haired Shirley girl with the little pointed chin and the big eyes that weren’t like the eyes of any other girl in Avonlea school.

Gilbert reached across the aisle, picked up the end of Anne’s long red braid, held it out at arm’s length and said in a piercing whisper:

“Carrots! Carrots!”

Then Anne looked at him with a vengeance!

She did more than look. She sprang to her feet, her bright fancies fallen into cureless ruin. She flashed one indignant glance at Gilbert from eyes whose angry sparkle was swiftly quenched in equally angry tears.

“You mean, hateful boy!” she exclaimed passionately. “How dare you!”



ENGLISH LANGUAGE ARTS**● Part 1: Reading Literature (cont.)**

And then—thwack! Anne had brought her slate down on Gilbert’s head and cracked it—slate not head—clear across.

. . . Mr. Phillips stalked down the aisle and laid his hand heavily on Anne’s shoulder. “Anne Shirley, what does this mean?” he said angrily. Anne returned no answer. It was asking too much of flesh and blood to expect her to tell before the whole school that she had been called “carrots.” Gilbert it was who spoke up stoutly.

“It was my fault Mr. Phillips. I teased her.”

Mr. Phillips paid no heed to Gilbert.

“I am sorry to see a pupil of mine displaying such a temper and such a vindictive spirit,” he said in a solemn tone, as if the mere fact of being a pupil of his ought to root out all evil passions from the hearts of small imperfect mortals. “Anne, go and stand on the platform in front of the blackboard for the rest of the afternoon.”

. . . Anne stood there the rest of the afternoon. . . . She did not cry or hang her head. Anger was still too hot in her heart for that and it sustained her amid all her agony of humiliation.... As for Gilbert Blythe, she would not even look at him. She would NEVER look at him again! She would never speak to him!!

1. Which of the following details reveals important information about Gilbert’s feelings for Anne?

- (A) He tells Mr. Phillips that he was teasing Anne.
- (B) He studies his history book.
- (C) He pins Ruby’s braid to the back of her seat.
- (D) He sits right across the aisle from Anne.

2. Mr. Phillips paid no heed to Gilbert. In this sentence, *heed* means

- (F) to ignore.
- (G) to anger.
- (H) to amuse.
- (J) to listen or pay attention.

3. What is the main reason Anne feels upset?

- (A) She wants Diana to stop talking.
- (B) Mr. Phillips moves Anne’s seat to the front of the classroom.
- (C) Gilbert calls her hair “carrots.”
- (D) Gilbert winks at Anne.

4. Ruby cries when Mr. Phillips glares at her. Then, Gilbert winks at Anne. Why?

- (F) because Mr. Phillips thinks Anne pulled a prank
- (G) because Gilbert fooled Mr. Phillips
- (H) because Anne is daydreaming
- (J) because Anne hit Gilbert on the head



ENGLISH LANGUAGE ARTS**● Part 1: Reading Literature (cont.)**

Directions: Use the story you read on pages 1–2 to choose the best answers to the questions.

5. **Anne does not cry or hang her head during her punishment because**
- (A) she becomes tired while standing still.
 - (B) she does not want Mr. Phillips to see her upset.
 - (C) she is too angry and proud to show her feelings.
 - (D) she is not upset.
6. **While Anne looks out the window at the water, she is *far away in a gorgeous dreamland*. Which word best describes how Anne feels?**
- (F) peaceful
 - (G) frustrated
 - (H) excited
 - (J) angry
7. **Which sentence helps readers infer Anne’s feelings for Gilbert?**
- (A) Gilbert Blythe was absorbed in stealthily pinning the long yellow braid of Ruby Gillis.
 - (B) “I think your Gilbert Blythe IS handsome.”
 - (C) Gilbert Blythe wasn’t used to putting himself out to make a girl look at him and meeting with failure.
 - (D) She would NEVER look at him again!
8. **Which sentence best summarizes this passage?**
- (F) Anne likes to tease Gilbert Blythe.
 - (G) Mr. Phillips accidentally punishes the wrong pupil.
 - (H) Gilbert Blythe wants Anne’s attention.
 - (J) Anne likes to daydream.
9. ***She flashed one indignant glance at Gilbert from eyes whose angry sparkle was swiftly quenched in equally angry tears.* In this sentence, *quenched* means**
- (A) cleaned.
 - (B) dried.
 - (C) overcome.
 - (D) wasted.
10. **Anne responds to Gilbert’s teasing with anger. The author intends for the reader to find the teasing**
- (F) upsetting.
 - (G) suspenseful.
 - (H) boring.
 - (J) humorous.



ENGLISH LANGUAGE ARTS**● Part 2: Reading Informational Text**

Directions: Read the text. Mark the best answers to the questions that follow.

Taxation Without Representation? Views on Colonial America

Views of a Twenty-First Century Historian

American colonists had no elected representatives in the British Parliament. Therefore, the British government had no right to tax the colonies. The British tried to raise money in 1765 by requiring a tax stamp on colonial documents, newspapers, and other printed papers. Colonists' opposition to the Stamp Act was justified. Colonists could not be taxed without being represented in Parliament. The Stamp Act obviously weakened the colonists' rights and liberties.

Patrick Henry's Resolutions Against the Stamp Act

Printed in the *Maryland Gazette*, July 4, 1765

. . . Resolved, therefore, That the General Assembly of this Colony, with the Consent of his Majesty, or his Substitute, HAVE the Sole Right and Authority to lay Taxes and Impositions upon Its Inhabitants: And, That every Attempt to vest such Authority in any other Person or Persons whatsoever, has a Manifest Tendency to Destroy AMERICAN FREEDOM.

That any Person who shall, by speaking, or writing, assert or maintain, that any Person or Persons, other than the General Assembly of this Colony, with such Consent as aforesaid, have any Right or Authority to lay or impose any Tax whatever on the Inhabitants thereof, shall be Deemed, AN ENEMY TO THIS HIS MAJESTY'S COLONY.

Views of Samuel Johnson, an English Writer

As man can be in but one place, at once, he cannot have the advantages of multiplied residence. He that will enjoy the brightness of sunshine, must quit the coolness of the shade. He who goes voluntarily to America, cannot complain of losing what he leaves in Europe. He, perhaps, had a right to vote for a knight or burgess; by crossing the Atlantick [sic], he has not nullified his right; but he has made its exertion no longer possible. By his own choice he has left a country, where he had a vote and a little property, for another, where he has great property, but no vote.



ENGLISH LANGUAGE ARTS**● Part 2: Reading Informational Text (cont.)**

Directions: Use the text you read on page 4 to choose the best answer for each question.

1. How does the last paragraph of Henry's passage show that he disapproves of the Stamp Act?

- (A) It shows how a man has great property, but no vote.
- (B) It defends the actions of the British Parliament.
- (C) It defines an enemy of the colony.
- (D) It states that the Stamp Act weakened colonists' rights.

2. How does Johnson distinguish between the voting rights of colonists and of Europeans?

- (F) He regards colonists as having the same voting rights as Europeans.
- (G) He argues that colonists chose to leave, giving up voting rights.
- (H) He states that the British government has no right to tax the colonies.
- (J) He does not make a distinction.

3. What evidence supports claims made by the historian about the unfairness of the Stamp Act?

- (A) The British government had no right to tax the colonies.
- (B) Colonists' opposition to the Stamp Act was justified.
- (C) The Stamp Act weakened the colonists' rights and liberties.
- (D) Americans had no elected representatives in Parliament.

4. Reread the first paragraph of *Patrick Henry's Resolutions Against the Stamp Act*. In this paragraph, *vest* means

- (F) to give.
- (G) to take away.
- (H) to return.
- (J) to elect.

5. *He that will enjoy the brightness of sunshine, must quit the coolness of the shade.* With this sentence, Johnson suggests that

- (A) Europeans should leave Europe.
- (B) a person can enjoy only the advantages of a single residence.
- (C) colonists should exert their right to vote in America.
- (D) he is upset by Patrick Henry's views.

6. On which of the following statements would Henry and Johnson disagree?

- (F) Colonists have a right to settle in America.
- (G) The British proposed the Stamp Act.
- (H) A country's ruler imposes taxes.
- (J) By leaving Europe, colonists gave up their right to representation.



ENGLISH LANGUAGE ARTS**● Part 2: Reading Informational Text (cont.)**

Directions: Use the text you read on page 4 to choose the best answer for each question.

7. After reading *Views of a Twenty-First Century Historian*, readers can infer that

- (A) the historian disagrees with the Stamp Act.
- (B) the historian agrees with the British Parliament.
- (C) the historian probably disagrees with Patrick Henry.
- (D) the historian probably agrees with Samuel Johnson.

8. Which sentence best summarizes these three passages?

- (F) Colonists and the British Parliament agreed on taxation.
- (G) Taxation was a divisive issue between colonists and the British.
- (H) Patrick Henry believed in colonial freedom.
- (J) Most colonists did not oppose the Stamp Act.

9. How might Henry respond to a challenge to his resolution?

- (A) He would consider the challenger an enemy of the colony.
- (B) He would consider the challenger an enemy of the British Parliament.
- (C) He would write another resolution.
- (D) He would support the Stamp Act.

10. *By his own choice he has left a country, where he had a vote and a little property, for another, where he has great property, but no vote.* How does this sentence convey Johnson's feelings about colonists?

- (F) Johnson feels colonists left Europe to get property.
- (G) Johnson feels that the Stamp Act is unfair.
- (H) Johnson feels that the colonists will find freedom.
- (J) Johnson feels colonists chose to leave Europe, and should accept the consequences.

11. In *Patrick Henry's Resolutions Against the Stamp Act*, Henry compares taxes to

- (A) authority.
- (B) freedom.
- (C) impositions.
- (D) inhabitants.

12. Based on these three passages, what might readers infer?

- (F) Taxation only affected the British Parliament.
- (G) Supporters and detractors of taxation without representation passionately defended their positions.
- (H) Colonists were wrong to oppose the Stamp Act.
- (J) Taxation did not affect many people.



ENGLISH LANGUAGE ARTS

● Part 3: Writing

Directions: On a separate piece of paper, write a response to each prompt. Include all the parts in the checklists.

1. Write an Argument

Write a composition explaining whether or not you think it is acceptable to text while riding a bicycle or driving a car.

Checklist:

Read what you wrote. Did you remember to do the following?

	Yes	No
Introduce your claim.	<input type="checkbox"/>	<input type="checkbox"/>
Clearly express your view and acknowledge the opposing view.	<input type="checkbox"/>	<input type="checkbox"/>
Present organized supporting reasons and evidence.	<input type="checkbox"/>	<input type="checkbox"/>
Use words such as <i>in addition</i> , <i>for example</i> , <i>on the other hand</i> , and <i>as a result</i> to link your claim with reasons.	<input type="checkbox"/>	<input type="checkbox"/>
Use a formal style.	<input type="checkbox"/>	<input type="checkbox"/>
Write a conclusion that supports your argument.	<input type="checkbox"/>	<input type="checkbox"/>

2. Write to Inform

Write a composition describing the career that most interests you.

Checklist:

Read what you wrote. Did you remember to do the following?

	Yes	No
Introduce and describe your topic.	<input type="checkbox"/>	<input type="checkbox"/>
Organize information into categories.	<input type="checkbox"/>	<input type="checkbox"/>

Develop each category with facts, examples, and other details.	<input type="checkbox"/>	<input type="checkbox"/>
Use precise language specific to your topic.	<input type="checkbox"/>	<input type="checkbox"/>
Use a formal style.	<input type="checkbox"/>	<input type="checkbox"/>
Give a concluding statement that supports your topic.	<input type="checkbox"/>	<input type="checkbox"/>

3. Write a Narrative

Choose a chapter or scene from your favorite book or movie. Retell the chapter or scene using yourself as one of the characters.

Checklist:

Read what you wrote. Did you remember to do the following?

	Yes	No
Capture readers' attention with a memorable opening that introduces important characters.	<input type="checkbox"/>	<input type="checkbox"/>
Organize the sequence of events logically.	<input type="checkbox"/>	<input type="checkbox"/>
Use elements such as dialogue and description to tell the story.	<input type="checkbox"/>	<input type="checkbox"/>
Use transition words to show shifts in the action and settings.	<input type="checkbox"/>	<input type="checkbox"/>
Use precise words and sensory language.	<input type="checkbox"/>	<input type="checkbox"/>
Conclude with a thoughtful ending.	<input type="checkbox"/>	<input type="checkbox"/>



ENGLISH LANGUAGE ARTS**● Part 4: Language****Directions:** Choose the best answer for each question.

1. Choose the sentence in which the underlined verb is a gerund that functions as a noun.
 - (A) Sitting in the balcony, I am able to see the entire stage.
 - (B) Jaden was winking at his friend.
 - (C) Running in the park is my favorite exercise.
 - (D) Being a doctor, she examined the wound.

2. In which sentence is the verb used in the passive voice?
 - (F) My parents drove us to the beach.
 - (G) Birds were flying along the shore.
 - (H) A ball was thrown to our dog.
 - (J) We enjoyed spending time together.

3. *I wonder if I could rock climb outdoors today.* This sentence
 - (A) indicates a fact or opinion.
 - (B) gives a command.
 - (C) asks a question.
 - (D) expresses a wish.

4. Which sentence has the subject *you*?
 - (F) The party will begin at 7:00.
 - (G) Be here at 7:00.
 - (H) I think 7:00 would be a good time to come.
 - (J) Everyone is arriving at 7:00.

5. Which sentence states a fact?
 - (A) I read *A Wrinkle in Time* last year.
 - (B) Have you read *A Wrinkle in Time*?
 - (C) Read *A Wrinkle in Time* over the summer.
 - (D) If Mr. P. were here, he might say that *A Wrinkle in Time* is the best book ever.

6. Choose the corrected version of the sentence.

The manager was been hired to complete the project.

 - (F) The manager had been hired to complete the project.
 - (G) The manager has hiring to complete the project.
 - (H) The manager hiring to complete the project.
 - (J) The manager have been hired to complete the project.



ENGLISH LANGUAGE ARTS**● Part 4: Language (cont.)****Directions:** Choose the best answer for each question.

7. Which is an example of an interrogative sentence?

- (A) I wish I had seen you at lunch yesterday.
- (B) Do you have plans for lunch today?
- (C) Meet me for lunch later.
- (D) I am looking forward to lunch today.

8. Choose the correctly spelled word.

- (F) definately
- (G) definetly
- (H) definitley
- (J) definitely

9. Choose a punctuation mark to make the sentence correct.

There are three essential ingredients in a delicious sandwich fresh bread, fresh vegetables, and mustard.

- (A) ?
- (B) ,
- (C) —
- (D) !

10. Choose the sentence that emphasizes an action.

- (F) It is important that the dog be walked each evening.
- (G) I wish she were the president.
- (H) If I were you, I would wear a jacket in the winter.
- (J) My best friend lives two miles away.

11. Choose the correctly spelled word that completes the sentence.

Unfortunately, it will be _____ to wake up early tomorrow morning.

- (A) necessary
- (B) neccessary
- (C) necessary
- (D) necessery

12. Choose the correct way to indicate the shortened form of the sentence.

I wanted to explain to Dylan, and even though it was Saturday, I wished I were at school so that we could see each other.

- (F) I wanted to explain to Dylan, and I wished I were at school so that we could see each other.
- (G) I wanted to explain to Dylan, and...I wished I were at school so that we could see each other.
- (H) I wanted to explain to Dylan, and..... I wished I were at school so that we could see each other.
- (J) I wanted to explain to Dylan. I wished I were at school so that we could see each other.



ENGLISH LANGUAGE ARTS**● Part 4: Language (cont.)****Directions:** Choose the best answer for each question.

13. Which sentence is the best example of the active voice?
- (A) One idea was submitted by Ying.
 - (B) Ying's idea has been submitted.
 - (C) Ying submitted her idea.
 - (D) Ying's idea is being considered by the judges.
14. The Greek root *biblos* means "book." Which word means "a list of books on a particular subject"?
- (F) library
 - (G) biography
 - (H) bookshelf
 - (J) bibliography
15. Choose the correctly spelled word that completes the sentence.
- Sasha visits her grandparents every weekend, but only _____ visits her cousins.
- (A) ocassionally
 - (B) occashionaly
 - (C) occasionally
 - (D) occationally
16. The Latin root *audio* means "hearing." Which word means "capable of being heard"?
- (F) audible
 - (G) audit
 - (H) auger
 - (J) audition
17. Which part of the dictionary entry for the word *vengeance* shows the part of speech?
- (A) <from Latin>
 - (B) \ven' jəns\
(C) *n.*
 - (D) 1. Retribution
18. Which does not contain a pun?
- (F) The rain was a blessing in disguise.
 - (G) The girl's teddy bear is not hungry because it is already stuffed.
 - (H) A day without geometry practice is pointless.
 - (J) Instead of paying the delivery person for the pizza, the duck said, "Put it on my bill."



ENGLISH LANGUAGE ARTS

● Part 4: Language (cont.)

Directions: Choose the best answer for each question.

19. Which best explains the figure of speech used in the title *The Hare's Hairy Adventures*?
- (A) A hare is not adventurous.
 - (B) Describing a hare as *hairy* is an exaggeration.
 - (C) A hare is not human, but the title suggests this.
 - (D) *Hare* and *hairy* are used as a play on homophones.

20. What does the analogy help you understand?

Numbers are to math as words are to language.

- (F) Numbers and words are used in a specific order.
- (G) Numbers and words are the basic parts of math and language.
- (H) *Numbers* and *words* are synonyms.
- (J) Numbers and words are not used in both math and language.

21. Which set does not contain words with similar meanings?

- (A) saunter, meander, walk, trot, strut
- (B) sinister, evil, insidious, dark, malicious
- (C) optimistic, sunny, cheerful, amicable, pleasant
- (D) gather, assemble, revolt, congregate, join

22. Choose the math term that best completes the sentence.

An equation that states two ratios are equal is called a _____.

- (F) square root
- (G) reflection
- (H) proportion
- (J) radius

23. In which sentence is the underlined verb a participle that functions as an adjective?

- (A) The trembling toddler was afraid of the storm.
- (B) The toddler trembled at the sounds of the storm.
- (C) The toddler kept trembling all through the storm.
- (D) The toddler often trembles with fear during storms.

24. Choose the infinitive form of the underlined verb.

Shilpa can't wait for the eighth grade picnic.

- (F) waited
- (G) to wait
- (H) waits
- (J) waiting



MATHEMATICS**● Part 1: The Number System****Directions:** Choose the best answer for each question.1. Which decimal is equivalent to $\frac{80}{37}$?

- (A) 0.4625
 (B) $2.16\overline{2}$
 (C) $2.1\overline{62}$
 (D) $2.\overline{162}$

2. Which fraction is equivalent to $0.\overline{296}$?

- (F) $\frac{37}{125}$
 (G) $2\frac{24}{25}$
 (H) $\frac{8}{27}$
 (J) $2\frac{96}{99}$

3. Which best describes the value of $\sqrt{197}$?

- (A) $\sqrt{197}$ is between 9.8 and 9.9.
 (B) $\sqrt{197}$ is between 11.3 and 11.4.
 (C) $\sqrt{197}$ is between 13.9 and 14.
 (D) $\sqrt{197}$ is between 14 and 14.1.

4. Three of these statements are true. Which one is false?

- (F) $\sqrt{60} > 7.8$
 (G) $\sqrt{72} > 8.2$
 (H) $\sqrt{84} > 8.6$
 (J) $\sqrt{88} > 9.2$

5. Which number is irrational?

- (A) $\frac{1}{3}$
 (B) 0.10011000111 ...
 (C) $6.\overline{18}$
 (D) $\sqrt{4}$

6. Which sequence shows numbers in order from least to greatest?

- (F) 7.4, $\sqrt{55}$, 7.5
 (G) 7.8, $\sqrt{59}$, 7.9
 (H) 8.0, $\sqrt{67}$, 8.1
 (J) 8.6, $\sqrt{71}$, 8.7

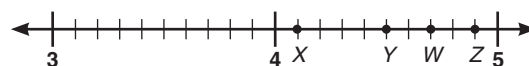
7. Which point shows the approximate location of $\sqrt{17}$ on the number line?

- (A) X
 (B) Y
 (C) W
 (D) Z



MATHEMATICS**● Part 2: Expressions and Equations****Directions:** Choose the best answer for each question.1. Simplify $2^4 \times 2^{-3} \times 2$.

- (A) 2
 (B) 4
 (C) 256
 (D) 4096

2. In 5 days, a bacteria colony increased in number from 4×10^3 to 9×10^6 . Approximately how many times larger is the colony after the increase?

- (F) 2
 (G) 20
 (H) 348
 (J) 2000

3. A one-liter water sample contains 1.95×10^{-7} grams of mercury. How much mercury would 1,000 liters of the water contain?

- (A) 1.95×10^{-21} grams
 (B) 1.95×10^{-10} grams
 (C) 1.95×10^{-4} grams
 (D) 1.95×10^4 grams

4. Simplify $\frac{(2 \times 10^6) \times (1.5 \times 10^2)}{6 \times 10^3}$.

What is the result in scientific notation?

- (F) 0.5×10^4
 (G) 0.5×10^6
 (H) 5×10^4
 (J) 5×10^5

5. Which two lines have the same slope?

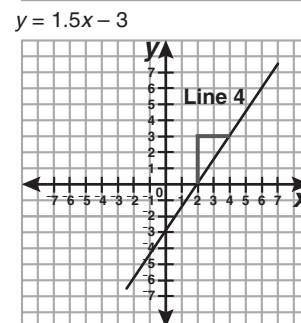
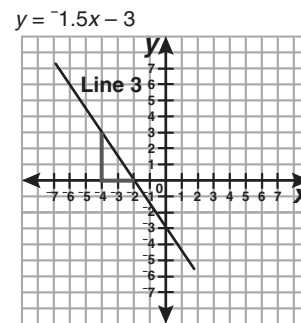
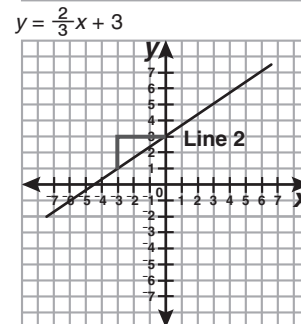
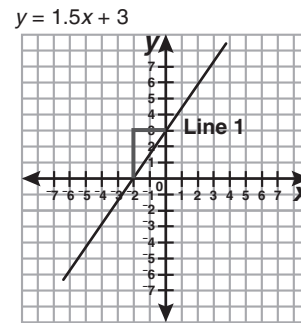

- (A) 1 and 2
 (B) 2 and 3
 (C) 1 and 4
 (D) 2 and 4



MATHEMATICS**● Part 2: Expressions and Equations (cont.)****Directions:** Choose the best answer for each question.

6. The graph shows the relationship between the distance a car travels and the amount of gasoline it uses. How far will the car travel on 1 gallon of gas?

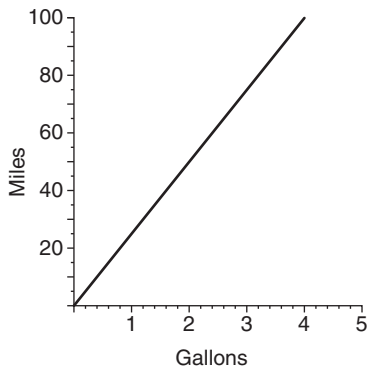

- (F) 4 miles
 (G) 18 miles
 (H) 25 miles
 (J) 50 miles
7. Which expression is equivalent to $\frac{1}{25}$?

- (A) $5\frac{1}{2}$
 (B) $(\frac{1}{5})^{-2}$
 (C) $5^3 \times 5^{-1}$
 (D) $5^2 \times 5^{-4}$

8. What is the solution to the equation $5x + 3 = 3(x + 1) + 2x$?

- (F) no solution
 (G) one solution: $x = 0$
 (H) one solution: $x = 1$
 (J) infinitely many solutions

9. Solve $x^3 = 64$ for x .

- (A) 2
 (B) 4
 (C) 8
 (D) $2\frac{1}{3}$

10. Which ordered pair is true for both $x - 2y = 1$ and $3x - 2y = 7$?

- (F) $(2, -\frac{1}{2})$
 (G) $(2, \frac{1}{2})$
 (H) (3, 1)
 (J) (5, 1)

11. Jerry has \$50 and spends \$5 each day. Linda has \$40 and spends \$3 each day. Complete the chart to help you determine on what day they will have the same amount of money.

Day	1	2	3	4	5
Jerry (50)					
Linda (40)					

- (A) on the 2nd day
 (B) on the 5th day
 (C) on the 10th day
 (D) on the 25th day



MATHEMATICS

● Part 2: Expressions and Equations (cont.)

Directions: Choose the best answer for each question.

12. If John buys 6 pounds of apples, it will cost \$7.50. If he buys 4 pounds of apples, it will cost \$5.00. Which graph shows the relationship between the weight of the apples and their cost?

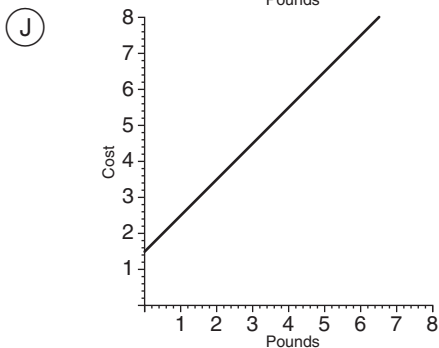
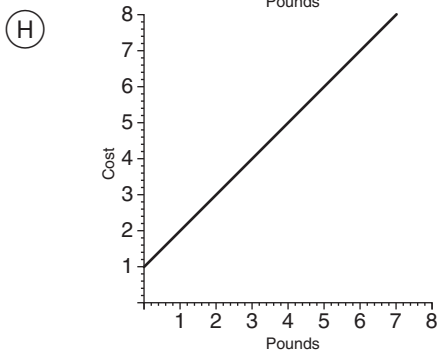
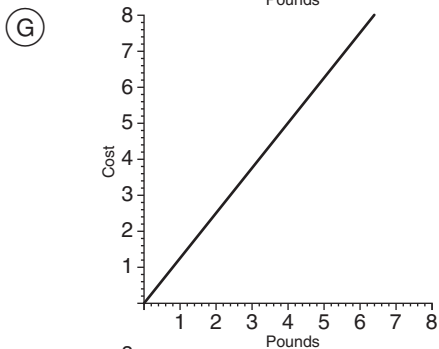
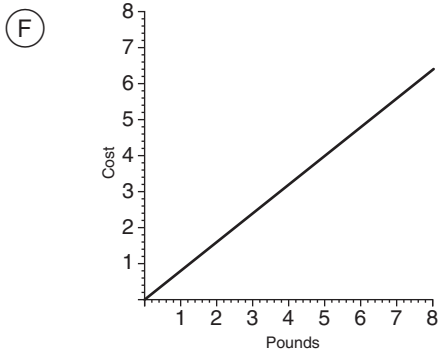

13. What is the solution of the equation $2x - 3 + 4x = 3(x - 1)$?

- (A) no solutions
- (B) one solution: $x = -1$
- (C) one solution: $x = 0$
- (D) infinitely many solutions

14. Solve the equation $-\frac{6}{10}(x - 4) = 0.4x - 2$.

- (F) $x = 4.4$
- (G) $x = -2$
- (H) $x = -2.2$
- (J) $x = -4.4$

15. Use the graph to find a solution for both $y = 2x - 5$ and $y = -2x + 3$.

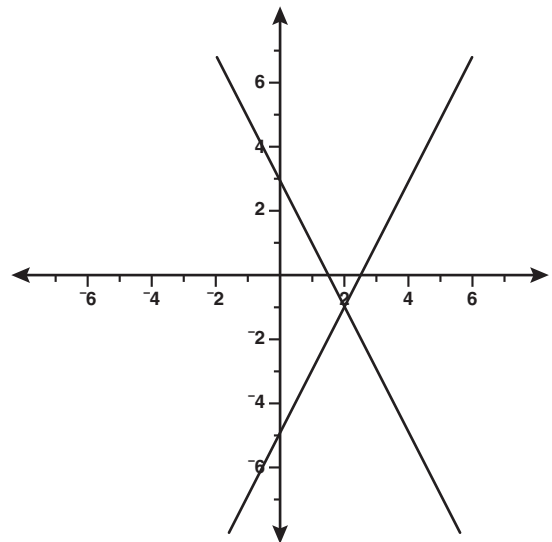

- (A) $(-5, 3)$
- (B) $(-1, 2)$
- (C) $(2, -1)$
- (D) $(3, -5)$



MATHEMATICS

● Part 3: Functions

Directions: Choose the best answer for each question.

1. Three of the tables show functions. Which is not a function?

(A)

Input	4	1	2	-8	9
Output	0	5	-9	8	6

(B)

Input	3	-9	8	5	8
Output	-6	6	8	9	-5

(C)

Input	2	7	8	-9	3
Output	7	7	-3	1	3

(D)

Input	2	-5	7	4	-2
Output	-2	4	5	5	-1

2. Which is the graph of a function?

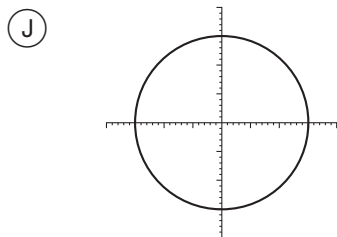
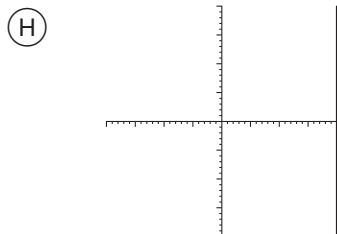
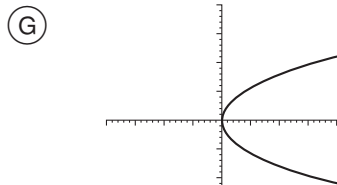
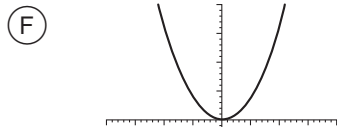

3. Which brand of pen is most expensive?

Brand A:

Number of Pens	2	6	5	8
Total Cost	\$5.00	\$15.00	\$12.50	\$20.00

Brand B:

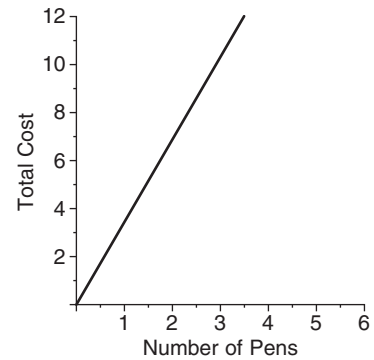

Brand C:

$C = 2p$, where p is the number of pens and C is the total cost.

Brand D:

Pens are sold to retailers by the case. Each case contains 12 cartons. Each carton contains 36 pens. One case costs \$972.

- (A) Brand A
- (B) Brand B
- (C) Brand C
- (D) Brand D

4. Which equation does not describe a linear function?

- (F) $y = 3$
- (G) $y = \frac{2}{3}x - \frac{1}{3}$
- (H) $y = \frac{2}{x} - 6$
- (J) $y = -x$



MATHEMATICS**● Part 3: Functions (cont.)****Directions:** Choose the best answer for each question.

5. Which equation describes a linear function?

(A) $y = \frac{1}{4}x - 2$

(B) $y = x^2 - 1$

(C) $y = \frac{3}{x} + 2$

(D) $y = \sqrt{x}$

6. Which equation could be used to describe this function table?

x	y
-2	-9
0	-5
3	1

(F) $y = \frac{1}{2}x - 5$

(G) $y = x - 7$

(H) $y = 2x - 5$

(J) $y = 3x - 3$

7. A frame shop determines the cost of glass using this function.

$C = 0.5a + 3$, where C is the total cost and a is the area of the glass in square inches.

What might 0.5 and 3 mean in the context of this problem?

- (A) It costs \$0.50 to cut the glass and \$3.00 for each square inch.
- (B) It costs \$0.50 for each square inch of glass and \$3.00 to cut it.
- (C) It costs \$3.50 for a piece of glass.
- (D) It costs \$3.50 for each square inch of glass.

8. On scrap paper, make equations and graphs to illustrate each situation. How would the graphs look?

Pedro has \$20 at the beginning of the week. Each day he spends \$3.

Alana has \$20 at the beginning of the week. Each day she earns \$3.

- (F) Pedro's graph would begin at (0, 20) and have a negative slope. Alana's graph would begin at (0, 0) and have a positive slope.
- (G) Pedro's graph would begin at (0, -20). Alana's graph would begin at (0, 20). The slopes would match.
- (H) Both graphs would begin at (0, 20). The slope of Pedro's graph would be negative, but the slope of Alana's graph would be positive.
- (J) Both graphs would begin at (0, 20). The slopes would match.

9. Maria starts to read a book with 630 pages. Every day, she reads 25 pages.

Which function describes the number of pages Maria has left to read? Let d represent the number of days she reads and p represent the number of pages remaining.

- (A) $p = 25d - 630$
- (B) $p = 630 - 25d$
- (C) $p = \frac{630}{d}$
- (D) $p = d(630 - 25)$



MATHEMATICS

● Part 3: Functions (cont.)

Directions: Choose the best answer for each question.

10. Which is the graph of this function?

Input (x)	-4	8	3	7	-3	1	5	-1
Output (y)	1	-6	7	5	-2	0	0	-5

(F)

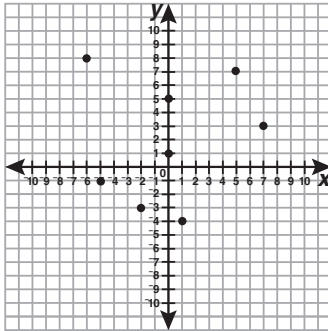

(G)

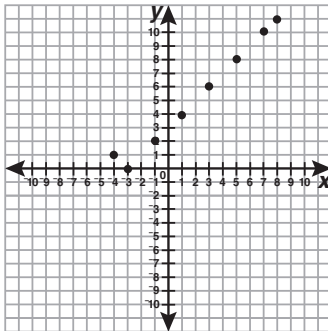

(H)

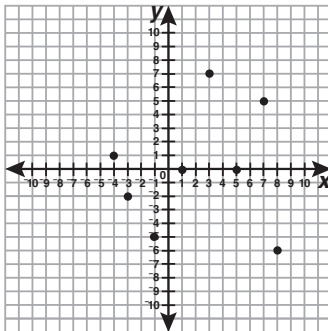

(J)

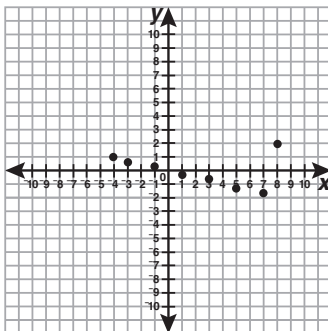

11. Which graph shows this situation?

Birdseed costs \$2 per pound if it weighs less than 20 pounds. Birdseed costs \$1.50 per pound if it weighs between 21 and 39 pounds. Birdseed costs \$1 per pound if it weighs over 40 pounds.

(A)

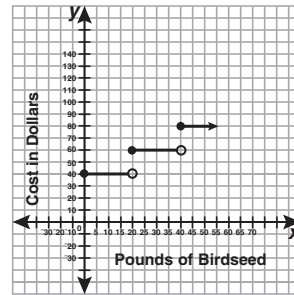

(B)

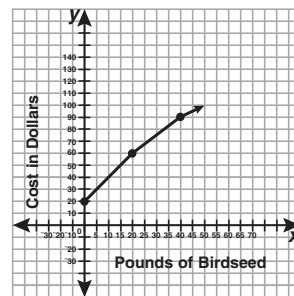

(C)

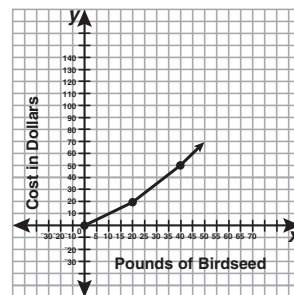

(D)

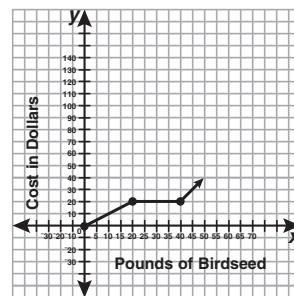

MATHEMATICS**● Part 4: Geometry****Directions:** Choose the best answer for each question.

1. Which of the following is a correct explanation of how to find the measure of $\angle 5$?

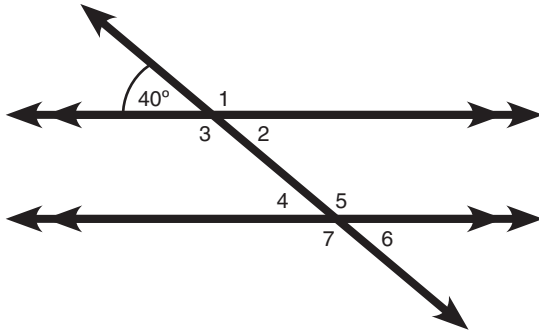

- (A) $\angle 2$ and the 40° angle are vertical angles, so the measure of $\angle 2$ is 40° . $\angle 2$ and $\angle 5$ are congruent because they are alternate interior angles, so the measure of $\angle 5$ is also 40° .
- (B) $\angle 3$ and the 40° angle are supplementary, so the measure of $\angle 3$ is 140° . $\angle 3$ and $\angle 5$ are congruent because they are alternate interior angles, so the measure of $\angle 5$ is also 140° .
- (C) $\angle 3$ and the 40° angle are supplementary, so the measure of $\angle 3$ is 140° . $\angle 3$ and $\angle 5$ are congruent because they are corresponding angles, so the measure of $\angle 5$ is also 140° .
- (D) $\angle 3$ and the 40° angle are supplementary, so the measure of $\angle 3$ is 40° . $\angle 3$ and $\angle 5$ are congruent because they are alternate interior angles, so the measure of $\angle 5$ is also 40° .

2. Robert says that the diagram shows a rotation of parallel lines. Brent disagrees. Who is correct?

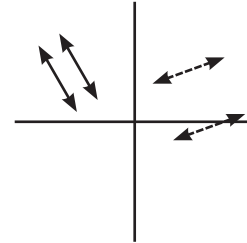

- (F) Robert is correct. The lines were rotated around the origin.
- (G) Brent is correct. The dashed lines are farther apart than the solid ones.
- (H) Brent is correct. The lines were translated, not rotated.
- (J) Brent is correct. You can only rotate one line, not a pair of lines.

3. Nelson walked halfway around the park from point A to point B and then to point C. Graham cut diagonally across the park from point A to point C. How much farther did Nelson walk than Graham?

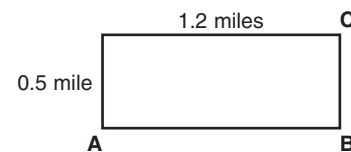

- (A) 0.01 mile
- (B) 0.4 mile
- (C) 1.3 miles
- (D) 3 miles



MATHEMATICS

● Part 4: Geometry (cont.)

Directions: Choose the best answer for each question.

4. Which series of translations can be used on figure A to get figure B?

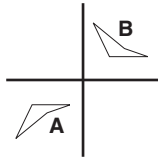

- (F) a vertical reflection and a translation to the right
- (G) a 90° clockwise rotation and a translation to the right
- (H) a 90° clockwise rotation and a horizontal reflection
- (J) The figures are not congruent, so it is not possible.

5. Which diagram shows the reflection of a line segment?

- (A)
- (B)
- (C)
- (D)

6. Which two quadrilaterals are similar?

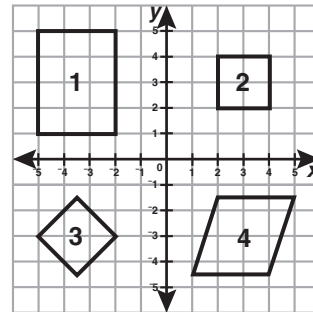

- (F) 1 and 4
- (G) 2 and 3
- (H) 2 and 4
- (J) None of them are similar.

7. Enrique wants to reflect the quadrilateral shown over the x-axis. What will be the coordinates of the reflected quadrilateral?

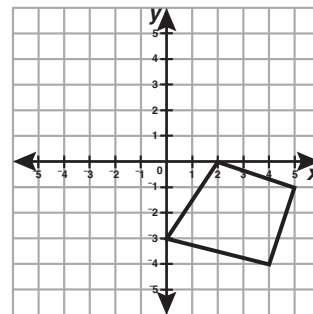

- (A) (2, 0), (0, -3), (4, -4), and (5, -1)
- (B) (-2, 0), (0, -3), (-4, -4), and (-5, -1)
- (C) (-2, 0), (0, 3), (-4, 4), and (-5, 1)
- (D) (2, 0), (0, 3), (4, 4), and (5, 1)



MATHEMATICS**● Part 4: Geometry (cont.)****Directions:** Choose the best answer for each question.

8. Which angle is a translation of
- $\angle 1$
- ?

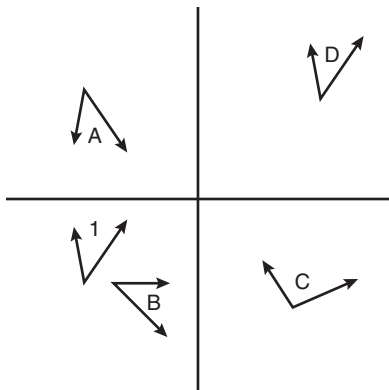

- (F) $\angle A$
 (G) $\angle B$
 (H) $\angle C$
 (J) $\angle D$

9. Mateo wants to buy a chair to fit in a corner. He wants the chair to be pulled out 15 inches from each wall as shown. To the nearest whole inch, how wide can the chair be?

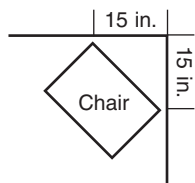

- (A) 15 inches
 (B) 21 inches
 (C) 30 inches
 (D) 45 inches

10. What is the distance between the two points?

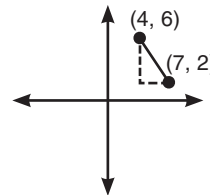

- (F) 5
 (G) 10
 (H) $\sqrt{201}$
 (J) 25

11. A paper cup that is shaped like a cone has a diameter of 3 inches and is 4 inches tall. How many cubic inches of water can it hold? Round your answer to the nearest whole number. (Hint: Use 3.14 for
- π
- .)

- (A) 9 cubic inches
 (B) 20 cubic inches
 (C) 28 cubic inches
 (D) 38 cubic inches

12. Alyssa has a thermos with a diameter of 8 centimeters and a height of 18 centimeters. How much soup can she put inside? (Hint: Use 3.14 for
- π
- .)

- (F) 226.08 cm^3
 (G) 904.32 cm^3
 (H) 3,617.28 cm^3
 (J) 903 cm^3



MATHEMATICS**● Part 5: Statistics and Probability**

Directions: Use Plots 1–4 to answer numbers 1–3. Use Plot 5 to answer numbers 4–6.

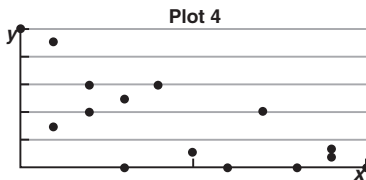
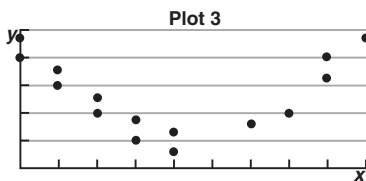
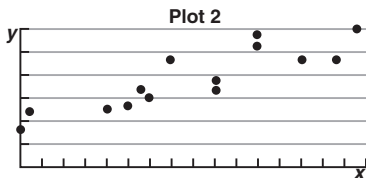
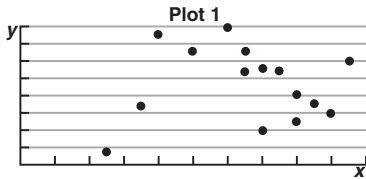

1. Which shows nonlinear association?

- (A) plot 1
- (B) plot 2
- (C) plot 3
- (D) plot 4

2. Which shows positive association?

- (F) plot 1
- (G) plot 2
- (H) plot 3
- (J) plot 4

3. Which shows no association?

- (A) plot 1
- (B) plot 2
- (C) plot 3
- (D) plot 4

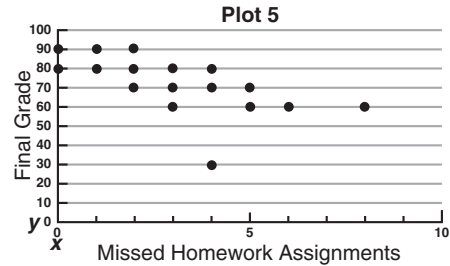

4. Mrs. Sanchez made Scatterplot 5 to compare her students' final grades with the number of homework assignments they did not do. What type of association does the scatterplot show?

- (F) linear positive association
- (G) linear negative association
- (H) nonlinear association
- (J) no association

5. Which of these equations could describe a line of best fit for the data?

- (A) $y = 85$
- (B) $y = -20x + 100$
- (C) $y = -4x + 90$
- (D) $y = x + 80$

6. Which point is an outlier?

- (F) (1, 90)
- (G) (4, 30)
- (H) (8, 60)
- (J) There are no outliers.



MATHEMATICS

Part 5: Statistics and Probability (cont.)

Directions: Use facts about Willa’s jewelry business to answer numbers 7–10.

Willa makes and sells jewelry. The amount she sells each piece for (y) is based on the amount she spends on materials (x). The equation $y = 2x + 5$ provides an approximation for the cost of each piece.

7. What might the 2 in $y = 2x + 5$ mean?

- (A) a \$2 service charge
- (B) \$2 more than the cost of materials
- (C) double the cost of the materials
- (D) twice what Willa charged last year

8. What might the 5 in $y = 2x + 5$ mean?

- (F) \$5 added after doubling the cost of materials
- (G) a \$5 discount on the materials
- (H) \$5 more than another jeweler charges
- (J) 5 times the cost of materials

9. If the cost of materials for a piece increases by \$6, about how much will the price increase?

- (A) \$17
- (B) \$5
- (C) \$6
- (D) \$12

10. Which scatterplot and line of best fit could illustrate Willa’s jewelry business?

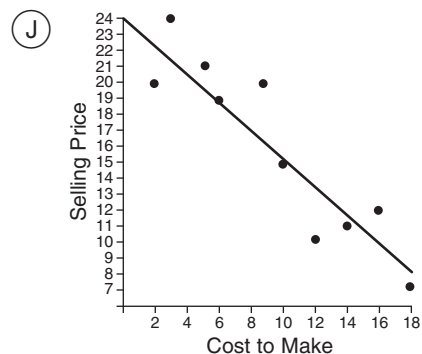
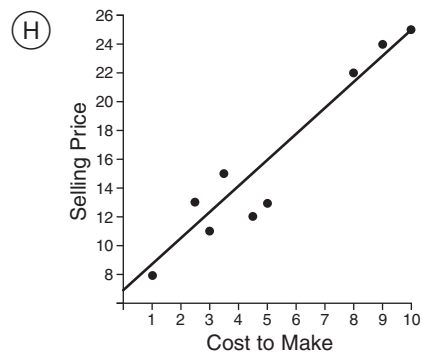
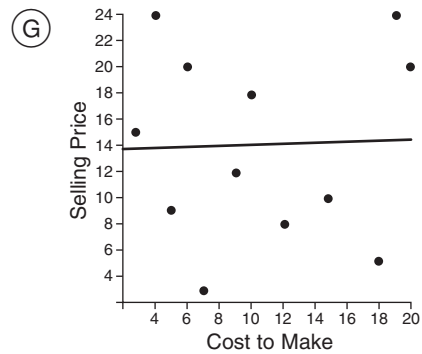
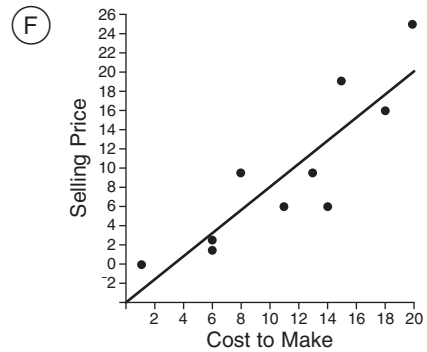

MATHEMATICS**● Part 5: Statistics and Probability (cont.)****Directions:** Use the survey results to answer numbers 11–14.**Do You Have Pets?**

	Yes	No
Apartment Residents	12	48
House Residents	24	16

11. What percentage of people who live in apartments have pets?

- (A) 12%
- (B) 20%
- (C) 25%
- (D) $33\frac{1}{3}\%$

12. What percentage of people who live in houses have pets?

- (F) 24%
- (G) $33\frac{1}{3}\%$
- (H) 60%
- (J) 150%

13. What percentage of pet owners live in apartments?

- (A) 12%
- (B) 20%
- (C) $33\frac{1}{3}\%$
- (D) 50%

14. Based on the survey, what can you conclude about pet ownership and where people live?

- (F) There is no correlation between where people live and whether or not they have pets.
- (G) Pets are not allowed in apartments.
- (H) People without pets are more likely to live in houses.
- (J) People who are pet owners are more likely to live in houses.



ANSWER KEY

English Language Arts

Part 1: Reading Literature

• Page 2

1. A
2. J
3. C
4. G

• Page 3

5. C
6. F
7. D
8. H
9. C
10. J

Part 2: Reading Informational Text

• Page 5

1. C
2. G
3. D
4. F
5. B
6. J

• Page 6

7. A
8. G
9. A
10. J
11. C
12. G

Part 4: Language

• Page 8

1. C
2. H
3. D
4. G
5. A
6. F

• Page 9

7. B
8. J
9. C
10. F
11. C
12. G

• Page 10

13. C
14. J
15. C
16. F
17. C
18. F

• Page 11

19. D
20. G
21. D
22. H
23. A

24. G

Mathematics

Part 1: The Number System

• Page 12

1. D
2. H
3. D
4. F
5. B
6. F
7. A

Part 2: Expressions and Equations

• Page 13

1. B
2. J
3. C
4. H
5. C

• Page 14

6. H
7. D
8. J
9. B
10. H
11. B

• Page 15

12. G
13. C
14. F
15. C

Part 3: Functions

• Page 16

1. B
2. F
3. B
4. H

• Page 17

5. A
6. H
7. B
8. H
9. B

• Page 18

10. H
11. B

Part 4: Geometry

• Page 19

1. B
2. G
3. B

• Page 20

4. F
5. C
6. G
7. D

• Page 21

8. J
9. B
10. F
11. A
12. G

Part 5: Statistics and Probability

• Page 22

1. C
2. G
3. A
4. G
5. C
6. G

• Page 23

7. C
8. F
9. D
10. H

• Page 24

11. B
12. H
13. C
14. J