

SPECTRUM[®] Test Practice

Comprehensive Practice Test

Minnesota Edition

Grade 5

The state of Minnesota has adopted the Common Core State Standards in English Language Arts only. For more information about Minnesota mathematics standards, use the links provided below.

In addition to the Common Core English Language Arts standards, Minnesota has adopted state-specific standards that make up no more than 15% of the total. Some items on this practice test are based on these state-specific standards. These questions are identified by a black circle around the item number, as shown below.

1. = Minnesota Standards Question

In fifth grade, Minnesota's standards encourage students:

- To use a writing process, including drafting.
- To distinguish between opinion and verifiable fact.
- To evaluate the accuracy and credibility of information from digital sources.

For more information:

Common Core State Standards Initiative:

<http://www.corestandards.org/>

Minnesota Department of Education K–12 Academic Standards:

<http://education.state.mn.us/MDE/EdExc/StanCurri/K-12AcademicStandards/index.htm>

MINNESOTA EDITION
Grade 5 Comprehensive Practice Test
COMMON CORE ENGLISH LANGUAGE ARTS

● **Part 1: Reading Literature**

Directions: Read the story. Mark the best answers to the questions that follow.

from My Father's Dragon

by Ruth Stiles Gannett

My father and the cat became good friends. . . .

Together they went for a walk in the park and tried to think of nice things to talk about. My father said, "When I grow up I'm going to have an airplane. Wouldn't it be wonderful to fly just anywhere you might think of!"

"Would you like to fly very, very much?" asked the cat.

"I certainly would. I'd do anything if I could fly."

"Well," said the cat, "if you'd really like to fly that much, I think I know of a sort of a way you might get to fly while you're still a little boy."

"You mean you know where I could get an airplane?"

"Well, not exactly an airplane, but something even better. As you can see, I'm an old cat now, but in my younger days I was quite a traveler. My traveling days are over but last spring I took just one more trip and sailed to the Island of Tangerina, stopping at the port of Cranberry. Well, it just so happened that I missed the boat, and while waiting for the next I thought I'd look around a bit. I was particularly interested in a place called Wild Island, which we had passed on our way to Tangerina. Wild Island and Tangerina are joined together by a long string of rocks, but people never go to Wild Island because it's mostly jungle and inhabited by very wild animals. So I decided to go across the rocks and explore it for myself. It certainly is an interesting place, but I saw something there that made me want to weep."

"Wild Island is practically cut in two by a very wide and muddy river," continued the cat. "This river begins near one end of the island and flows into the ocean at the other. Now the animals there are very lazy, and they used to hate having to go all the way around the beginning of this river to get to the other side of the island. It made visiting inconvenient and mail deliveries slow, particularly during the Christmas rush. Crocodiles could have carried passengers and mail across the river, but crocodiles are very moody, and not the least bit dependable, and are always looking for something to eat. They don't care if the animals have to walk around the river, so that's just what the animals did for many years."

"But what does all this have to do with airplanes?" asked my father, who thought the cat was taking an awfully long time to explain.



COMMON CORE ENGLISH LANGUAGE ARTS**● Part 1: Reading Literature (cont.)**

“Be patient, Elmer,” said the cat, and she went on with the story. “One day about four months before I arrived on Wild Island a baby dragon fell from a low-flying cloud onto the bank of the river. He was too young to fly very well, and besides, he had bruised one wing quite badly, so he couldn’t get back to his cloud. The animals found him soon afterwards and everybody said, ‘Why, this is just exactly what we’ve needed all these years!’ They tied a big rope around his neck and waited for the wing to get well. This was going to end all their crossing-the-river troubles.”

... “Oh, how wonderful!” said my father. “What did the animals do with him when his wing got well?”

“They started training him to carry passengers, and even though he is just a baby dragon, they work him all day and all night too sometimes. They make him carry loads that are much too heavy, and if he complains, they twist his wings and beat him. He’s always tied to a stake on a rope just long enough to go across the river. His only friends are the crocodiles, who say ‘Hello’ to him once a week if they don’t forget. Really, he’s the most miserable animal I’ve ever come across. When I left I promised I’d try to help him someday, although I couldn’t see how. The rope around his neck is about the biggest, toughest rope you can imagine, with so many knots it would take days to untie them all.

“Anyway, when you were talking about airplanes, you gave me a good idea. Now, I’m quite sure that if you were able to rescue the dragon, which wouldn’t be the least bit easy, he’d let you ride him most anywhere, provided you were nice to him, of course. How about trying it?”

1. Which best explains why the animals could not get across the river?

- (A) Crocodiles could have carried passengers and mail across the river, . . .
- (B) . . . he had bruised one wing quite badly, . . .
- (C) . . . crocodiles are very moody and not the least bit dependable, . . .
- (D) They make him carry loads that are much too heavy . . .

2. What is the theme of this excerpt from the story?

- (F) Crocodiles are not dependable animals.
- (G) It is wrong to treat animals cruelly.
- (H) Cats like to go on adventures.
- (J) It isn’t easy to get what you want.



COMMON CORE ENGLISH LANGUAGE ARTS**● Part 1: Reading Literature (cont.)**

Directions: Use the story you read on pages 1–2 to choose the best answer for each question.

3. How are Tangerina and Wild Island alike?

- (A) They both have dragons.
- (B) They are both wild.
- (C) They both have airplanes.
- (D) They are both islands.

4. In this story, what does *miserable* mean?

- (F) content
- (G) suffering
- (H) hard-working
- (J) moody

5. Why does the cat's adventure make her want to weep?

- (A) She thinks the animals are lazy.
- (B) She is annoyed at the crocodiles.
- (C) She feels sorry for the dragon.
- (D) She wants the animals to be able to cross the river.

6. Later in *My Father's Dragon*, Elmer travels to Wild Island to try and rescue the dragon. In what part of the book does this excerpt likely appear?

- (F) before Elmer meets the dragon
- (G) while the cat is having an adventure on Wild Island
- (H) after Elmer meets the dragon
- (J) while Elmer is having an adventure on Wild Island

7. How does the cat keep Elmer interested in the story?

- (A) by telling Elmer what he should do right away
- (B) by making the story interesting and full of details
- (C) by telling Elmer to be patient
- (D) by talking about how lazy the animals are

8. What visual element would best illustrate this excerpt?

- (F) a map of Wild Island
- (G) a photograph of a crocodile
- (H) a graph about air travel
- (J) a time line of the cat's adventure



COMMON CORE ENGLISH LANGUAGE ARTS**● Part 1: Reading Literature (cont.)**

Directions: Use the story you read on pages 1–2 to choose the best answer for each question.

9. Which phrase or sentence from the text best shows that rescuing the dragon will be difficult?

- (A) They make him carry loads that are much too heavy, and if he complains, they twist his wings and beat him.
- (B) When I left I promised I'd try to help him someday, although I couldn't see how.
- (C) Now, I'm quite sure that if you were able to rescue the dragon, which wouldn't be the least bit easy, . . .
- (D) . . . he'd let you ride him most anywhere, provided you were nice to him, of course.

10. How does the cat want Elmer to feel about the dragon?

- (F) sympathetic
- (G) afraid
- (H) uncaring
- (J) mean

11. Choose the best word to complete the sentence.

The cat wants to weep because she sees something _____ on Wild Island.

- (A) exciting
- (B) depressing
- (C) funny
- (D) cheerful

12. Choose the best word to complete the sentence.

The islanders are mean to the dragon and treat him _____.

- (F) carefully
- (G) kindly
- (H) strangely
- (J) cruelly

13. *My Father's Dragon* is an adventure story. Which detail best identifies this genre?

- (A) a mystery to be solved
- (B) travel to a faraway place where exciting things happen
- (C) characters and actions based on historical events
- (D) everyday problems and situations

14. Which is not a way the cat shows sympathy for the dragon?

- (F) She promises to help the dragon someday.
- (G) She suggests that Elmer rescue the dragon.
- (H) She tries to untie the dragon's rope.
- (J) She learns details about the dragon's plight.



COMMON CORE ENGLISH LANGUAGE ARTS**● Part 2: Reading Informational Text**

Directions: Read the texts. Choose the best answers for the questions that follow.

Moon Mystery

On a clear night, go outside and look for the moon. Do the same thing again a week later, and the moon you see will look different. It is the same familiar, rocky sphere that has been circling Earth for millions of years, so why does it always seem to change shape?

Sometimes, the moon is a bright disk that illuminates the night sky. Other times, it is just a sliver of white. Sometimes, the moon can be seen during the day. Other times, it is not visible at all. These different amounts of visibility are called the phases of the moon. They occur because the sun, the moon, and Earth are always moving.

One thing that almost never changes, however, is that the sun lights up one side of the moon. Because we live on the surface of Earth, the moon's appearance changes depending on how much of that illumination we can see. For example, a full moon occurs when the moon and the sun are on opposite sides of Earth and we are able to look directly at the lighted side of the moon.

A new, or dark, moon occurs when the moon and the sun are on the same side of Earth. In this case, we are looking directly at the unlit side of the moon that is facing away from the sun and is in shadow. The other phases occur as the moon orbits Earth and we see more or less of the illuminated half. A half-moon is when the moon is to the side of Earth, and you can see equal amounts of the lit and unlit halves.

A lunar eclipse is the only time the sun's light is prevented from reaching the moon. This occurs when the sun, the moon, and Earth are in a straight line with Earth in the middle. As the moon travels into the darkness of Earth's shadow, it seems as though all or part of it disappears.

A solar eclipse is slightly different. It occurs when the sun, the moon, and Earth are lined up, but the moon is in the middle. Although the sun is many times larger than the moon, it is also much, much farther away. This makes the sun and the moon appear to be the same size. When the moon's path goes in front of the sun, it temporarily blocks the sun and causes a solar eclipse. A solar eclipse is much more rare than a lunar eclipse.

Although there is still some debate, many scientists believe that the moon was once part of Earth. Millions of years ago, something crashed into Earth and broke off a large section of the planet. Gravity kept this huge chunk from floating away into space, and it became our moon. One strong piece of evidence that supports this theory is that the moon is made of the same materials as Earth.



COMMON CORE ENGLISH LANGUAGE ARTS**● Part 2: Reading Informational Text (cont.)*****A Solar Eclipse in Ancient China***

The earliest recorded solar eclipse was in ancient China. The date, often given as October 22, 2134 BC, is not certain. The ancient document *Shu Ching* records that “the Sun and Moon did not meet harmoniously.” The story says that two royal astronomers, Hsi and Ho, neglected their duties and failed to predict the event. A common belief was that an eclipse was caused by an invisible dragon devouring the Sun. A custom began of using lots of noise and activity (such as drumming and shooting arrows into the air) to frighten away the dragon and restore daylight. When this eclipse took place, the emperor was caught unprepared. Even though the Sun returned, the angry ruler ordered the astronomers beheaded!

- Which statement best explains why the moon does not always look the same?**
 - Sometimes, the moon illuminates the night sky.
 - A lunar eclipse is the only time the sun’s light is prevented from reaching the moon.
 - The sun, the moon, and Earth are always moving.
 - The sun lights up the moon.
- Which statements best sum up the main ideas of *Moon Mystery*?**
 - The moon seems to change shape. The movement of the sun, the moon, and Earth make the moon look different.
 - Solar eclipses are rare. Lunar eclipses are common.
 - The moon changes shape. The moon has different phases.
 - The moon was once part of Earth. The moon and Earth are made out of the same materials.
- What are the positions of the moon, Earth, and sun during a lunar eclipse?**
 - They are in a straight line with the moon in the middle.
 - They are in a straight line with Earth in the middle.
 - They are not in a straight line with the moon in the middle.
 - They are not in a straight line with Earth in the middle.
- Which two types of organization are used in *Moon Mystery* and *A Solar Eclipse in Ancient China*?**
 - cause and effect, compare and contrast
 - cause and effect, narrative
 - main idea and details, problem and solution
 - problem and solution, compare and contrast



COMMON CORE ENGLISH LANGUAGE ARTS**● Part 2: Reading Informational Text (cont.)**

Directions: Use the texts you read on pages 5–6 to choose the best answer for each question.

5. **What is the difference between our explanation of a solar eclipse and the explanation believed by the ancient Chinese?**
- (A) The ancients blamed astronomers, but we know that Earth blocks the sun.
 - (B) The ancients were frightened by an eclipse, but we are not frightened.
 - (C) The ancients believed a dragon was devouring the sun, but we know the moon blocks the sun.
 - (D) The ancients did not have an explanation for an eclipse, but we have an explanation for an eclipse.
6. **What would not be a good source to find out more about the moon?**
- (F) a Web site about the solar system
 - (G) an article about lunar eclipses
 - (H) an interview with an astronomer
 - (J) a novel about outer space
7. **Which event is least common?**
- (A) a new moon
 - (B) a full moon
 - (C) a lunar eclipse
 - (D) a solar eclipse
8. **After reading both texts, what do you know about solar eclipses?**
- (F) Solar eclipses are different from lunar eclipses.
 - (G) Today we understand solar eclipses better than people did in the past.
 - (H) Solar eclipses are caused by dragons.
 - (J) Ancient people made up stories to explain solar eclipses.
9. **Why did the Chinese emperor have the astronomers killed?**
- (A) He believed they had caused the eclipse.
 - (B) They did not warn him about the eclipse.
 - (C) They did not make enough noise to scare away the dragon.
 - (D) He thought the sun would never return.
10. **Why do the sun and the moon look like they are the same size?**
- (F) They are the same size.
 - (G) The sun is closer to Earth than the moon is.
 - (H) The moon is closer to Earth than the sun is.
 - (J) The moon's path changes as it moves around Earth.



COMMON CORE ENGLISH LANGUAGE ARTS**● Part 2: Reading Informational Text (cont.)**

Directions: Use the texts you read on pages 5–6 to choose the best answer for each question.

11. What is the position of the moon during a solar eclipse?

- (A) between Earth and the sun
- (B) behind Earth
- (C) to the left of the sun
- (D) to the right of the sun

12. What does *lunar* mean?

- (F) having to do with Earth
- (G) having to do with the sun
- (H) having to do with the moon
- (J) having to do with the sky

13. Which statement best explains why we cannot see a new moon?

- (A) We are looking directly at the unlit side of the moon that is facing away from the sun and is in shadow.
- (B) The sun lights up one side of the moon.
- (C) The moon orbits Earth and we see more or less of the illuminated half.
- (D) As the moon travels into the darkness of Earth's shadow, it seems as though all or part of it disappears.

14. Choose the fact.

- (F) A full moon is beautiful.
- (G) Solar eclipses are scary.
- (H) Sometimes, the moon can be seen during the day.
- (J) It is fascinating to gaze at the moon.

15. Choose the sentence that provides the strongest support for the opinion that the moon was once part of Earth.

- (A) The moon is made of the same materials as Earth.
- (B) The moon orbits Earth.
- (C) The moon can be seen from Earth.
- (D) The moon sometimes blocks the sun.

16. Choose the best word to complete the sentence.

People who lived long ago in _____ times had a limited understanding of our solar system.

- (F) current
- (G) ancient
- (H) modern
- (J) contemporary



COMMON CORE ENGLISH LANGUAGE ARTS

● Part 3: Writing

Directions: On a separate piece of paper, write a response to each prompt. Include all the parts in the checklists.

1. Write an Opinion

Imagine your school has decided to cut each physical education class by 15 minutes in order to allow more time for learning in the classroom. Write a letter to your principal expressing your opinion about the decision.

Checklist:

Read what you wrote. Did you remember to do the following?

	Yes	No
State your opinion.	<input type="checkbox"/>	<input type="checkbox"/>
Include well-organized reasons, facts, examples, and details that support your opinion.	<input type="checkbox"/>	<input type="checkbox"/>
Include words such as <i>consequently</i> and <i>specifically</i> to link your opinions with reasons.	<input type="checkbox"/>	<input type="checkbox"/>
Write a strong conclusion that summarizes your opinion.	<input type="checkbox"/>	<input type="checkbox"/>

2. Write to Inform

Write an article for the newspaper providing information about an event that has happened at your school or that will soon happen at your school.

Checklist:

Read what you wrote. Did you remember to do the following?

	Yes	No
Introduce the topic clearly.	<input type="checkbox"/>	<input type="checkbox"/>

Include headings, charts, or illustrations if they will help the reader understand.

Include facts, definitions, examples, and details that are organized logically.

Use words such as *in contrast* and *especially* to link ideas.

Write a concluding statement.

3. Write a Narrative

Write about a competition in which you have been a participant. Make sure to focus on the action, and explain your thoughts and feelings during the event.

Checklist:

Read what you wrote. Did you remember to do the following?

	Yes	No
Establish the situation and introduce characters.	<input type="checkbox"/>	<input type="checkbox"/>
Use techniques such as dialogue, description, and pacing to develop the story.	<input type="checkbox"/>	<input type="checkbox"/>
Include words and phrases that show the sequence of events.	<input type="checkbox"/>	<input type="checkbox"/>
Provide sensory details.	<input type="checkbox"/>	<input type="checkbox"/>
Write a good ending.	<input type="checkbox"/>	<input type="checkbox"/>



COMMON CORE ENGLISH LANGUAGE ARTS

● Part 4: Language

Directions: Choose the best answer for each question.

1. Which reference material provides the pronunciation of a word?

- (A) an atlas
- (B) an index
- (C) a dictionary
- (D) an encyclopedia

2. What does the expression *she is as pretty as a picture* mean?

- (F) She is painted in a picture.
- (G) She has had her picture taken.
- (H) She looks like someone in a picture.
- (J) She is very beautiful.

3. What does the expression *the early bird gets the worm* mean?

- (A) Birds get up early to look for worms.
- (B) If you get up early, you can have a good breakfast.
- (C) If you start early, you can get things done before other people.
- (D) You should get up early just like the birds do.

4. Which word best completes the sentence?

Dad said we had time to go to the mall _____ to the park, but not both.

- (F) and
- (G) but
- (H) or
- (J) by

5. Which word best completes the sentence?

Put the box _____ the bed so no one can see it.

- (A) under
- (B) above
- (C) next to
- (D) on top of

6. Which phrase best completes the sentence?

The cat _____ birth to five kittens last week.

- (F) has gave
- (G) had given
- (H) have given
- (J) has given



COMMON CORE ENGLISH LANGUAGE ARTS**● Part 4: Language (cont.)****Directions:** Choose the best answer for each question.

7. Which word best completes the sentence?

Felipe _____ in the race last week.

- (A) ran
- (B) runs
- (C) run
- (D) has run

8. Which word best completes the sentence?

Neither Marcus _____ Olivia can come to the party.

- (F) or
- (G) nor
- (H) and
- (J) but

9. Which sentence is incorrect?

- (A) The class went on a trip and saw animals at the zoo.
- (B) The class will go on a trip and see animals at the zoo.
- (C) The class wants to go on a trip to see animals at the zoo.
- (D) The class went on a trip and sees animals at the zoo.

10. Which sentence is punctuated correctly?

- (F) John, Harry, Jayden, and Fred are all in my class.
- (G) John, Harry Jayden, and Fred are all in my class.
- (H) John Harry Jayden, and, Fred are all in my class.
- (J) John Harry Jayden and Fred are all in my class.

11. Which sentence is punctuated correctly?

- (A) In the backyard of my house, there are seven cherry trees.
- (B) In the backyard, of my house there are seven cherry trees.
- (C) In the backyard of my house there are seven cherry, trees.
- (D) In the backyard of my house there are, seven cherry trees.

12. Which sentence is punctuated correctly?

- (F) Yes I am here to take the math test.
- (G) Yes, I am here to take the math test.
- (H) Yes I am, here to take the math test.
- (J) Yes, I am here, to take the math test.



COMMON CORE ENGLISH LANGUAGE ARTS**● Part 4: Language (cont.)****Directions:** Choose the best answer for each question.**13. Which sentence is punctuated correctly?**

- (A) You are going to come aren't you?
- (B) You are going, to come aren't you?
- (C) You are going to come, aren't you?
- (D) You are going to come aren't, you?

14. Which sentence is punctuated correctly?

- (F) Are you coming to the party Stephanie?
- (G) Are you coming, to the party Stephanie?
- (H) Are you coming to the party, Stephanie?
- (J) Are you coming, to the party, Stephanie?

15. Which sentence is correct?

- (A) I chose the poem summer days from the book Lemonade Stand.
- (B) I chose the poem Summer Days from the book *Lemonade Stand*.
- (C) I chose the poem *Summer Days* from the book "Lemonade Stand."
- (D) I chose the poem "Summer Days" from the book *Lemonade Stand*.

16. Which sentence was written after checking spellings in a dictionary?

- (F) My little brother broke the propeler on my model plane.
- (G) Jenna wore her new sandels.
- (H) My puppy is very stubborn!
- (J) The steps were entireley covered with flowers.

17. Which best combines the sentences?**The boys went to the park. It was a nice day. They flew kites.**

- (A) The boys went to the park on a nice day. They flew kites.
- (B) The boys went to the park. It was a nice day to fly kites.
- (C) The boys went to the park on a nice day to fly kites.
- (D) The boys went to the park it was a nice day they flew kites.

18. Which best combines the sentences?**The ball flew out of the field. It went into the stands. Lin caught the ball.**

- (F) The ball flew out of the field and then went into the stands where Lin caught the ball.
- (G) Lin caught the ball that flew out of the field and into the stands.
- (H) The ball flew out of the field and into the stands so Lin could catch it.
- (J) Lin caught the ball because it went into the stands after it flew out of the field.



COMMON CORE ENGLISH LANGUAGE ARTS

● Part 4: Language (cont.)

Directions: Choose the best answer for each question.

19. Which sentence is correct?

- (A) Mom had eaten five peaches by the time I got home.
- (B) Mom eats five peaches by the time I got home.
- (C) Mom had eat five peaches by the time I got home.
- (D) Mom will have ate five peaches by the time I got home.

20. Which is a synonym for the underlined word?

Christopher enclosed his yard so his dog would not run away.

- (F) opened
- (G) enlarged
- (H) fenced
- (J) circled

21. The Greek root *chronos* means “time.” What does *chronicle* mean?

- (A) clocks or watches
- (B) events that happened later
- (C) things that move clockwise
- (D) a list of events in the order that they happened

22. Which gives the meaning of the sentence?

Minute differences in the leaves of the two plants can be seen by observing for a minute.

- (F) Changing differences can be seen by extended watching.
- (G) Obvious differences can be seen by watching for sixty seconds.
- (H) Tiny differences can be seen by watching for sixty seconds.
- (J) Unimportant differences can be seen by watching for a while.

23. Which word best completes the sentence?

Marcus was on time; _____, his brother arrived late.

- (A) nevertheless
- (B) similarly
- (C) in addition
- (D) however

24. Which word best completes the sentence?

_____ Christina was shy, she gave a very good speech.

- (F) Although
- (G) Nevertheless
- (H) However
- (J) Moreover



MATHEMATICS**● Part 1: Operations and Algebraic Thinking****Directions:** Choose the best answer for each question.

1. Which expression matches the statement below?

Add ten to the product of three and two.

- (A) $10 + (3 + 2)$
(B) $10 \times (3 \times 2)$
(C) $10 + (3 \times 2)$
(D) $10 - (3 \times 2)$

2. What number is equal to the expression $9(6 + 2) - 7(4)$?

- (F) 44
(G) 46
(H) 54
(J) 56

3. Which sets of ordered pairs match the rules given below?

$x + 3$ and $x + 2$

- (A) (0, 0), (1, 3), (2, 6) and (0, 0), (1, 2), (2, 3)
(B) (0, 3), (1, 4), (2, 5) and (0, 2), (1, 3), (2, 4)
(C) (0, 3), (1, 5), (2, 6) and (0, 0), (1, 2), (2, 4)
(D) (0, 0), (1, 4), (2, 5) and (0, 2), (1, 4), (2, 5)

4. Which expression matches the statement below?

Multiply five by nine, then add twenty.

- (F) $(5 \times 9) - 20$
(G) $(5 + 9) + 20$
(H) $(5 \times 9) \times 20$
(J) $(5 \times 9) + 20$

5. What number is equal to the expression $9(7) - (11 - 3)$?

- (A) 49
(B) 55
(C) 65
(D) 71

6. Which sets of ordered pairs match the rules given below?

$x - 1$ and $x - 3$

- (F) (6, 7), (7, 8), (8, 9) and (6, 9), (7, 10), (8, 11)
(G) (6, 4), (7, 5), (8, 6) and (6, 3), (7, 4), (8, 5)
(H) (6, 5), (7, 6), (8, 7) and (6, 4), (7, 5), (8, 6)
(J) (6, 5), (7, 6), (8, 7) and (6, 3), (7, 4), (8, 5)



MATHEMATICS**● Part 1: Operations and Algebraic Thinking (cont.)****Directions:** Choose the best answer for each question.

7. What number is equal to the expression $[48 \div (3 + 9)] + 7(3)$?

(A) 17
 (B) 21
 (C) 24
 (D) 25

8. What number is equal to the expression $[37 - (8 + 6)] + 4(9)$?

(F) 58
 (G) 73
 (H) 59
 (J) 87

9. Which matches the expression $(48 \div 8) + 16$?

(A) Divide forty-eight by eight, then add sixteen.
 (B) Divide forty-eight by six, then add sixteen.
 (C) Divide forty-eight by eight, then subtract sixteen.
 (D) Divide forty-eight by eight, then multiply by sixteen.

10. Which matches the expression $2 \times (12 - 5)$?

(F) two times the difference of twelve and five
 (G) two times the sum of twelve and five
 (H) two times twelve and five
 (J) two times the product of twelve and five

11. What pattern was used to create the x and y values shown?

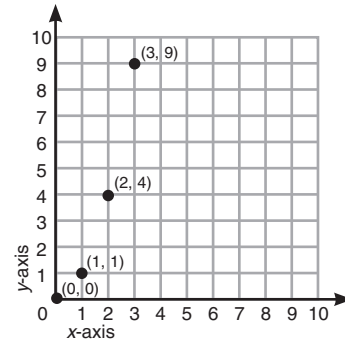

- (A) Add 1 to the previous x value to find the next x value, and add 1 to the previous y value to find the next y value.
 (B) Add 1 to the previous x value to find the next x value, and multiply the x value by 1 to find the y value.
 (C) Add 1 to the previous x value to find the next x value, and multiply the x value by 2 to find the y value.
 (D) Add 1 to the previous x value to find the next x value, and multiply the x value by itself to find the y value.

12. What number is equal to the expression $100 - [3(6 + 2) + 44]$?

(F) 28
 (G) 30
 (H) 32
 (J) 42

STOP

MATHEMATICS

● Part 2: Number and Operations in Base Ten

Directions: Choose the best answer for each question.

1. A grocery store sells packages of turkey burgers. There are 6 burgers in each package. If the store sold 1,296 turkey burgers over a week, how many packages were sold?

- (A) 232 packages
- (B) 222 packages
- (C) 216 packages
- (D) 214 packages

2. Amy buys 0.96 kilogram of cheese. If her family eats 0.24 kilogram, how much cheese is left? Use the graph to help you.

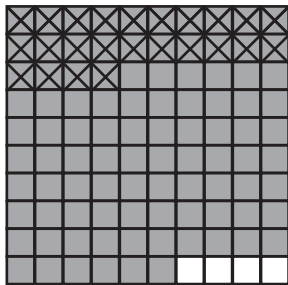

- (F) 0.72 kg
- (G) 0.73 kg
- (H) 1.2 kg
- (J) 1.3 kg

3. Which shows 19.628 written in expanded form?

- (A) $1 \times 10 + 9 \times (\frac{1}{10}) + 6 \times (\frac{1}{100}) + 2 \times (\frac{1}{1000})$
- (B) $1 \times 10,000 + 9 \times 1,000 + 6 \times 100 + 2 \times 10 + 2 \times 1000$
- (C) $1 \times 10 + 9 \times 1 + 6 \times (\frac{1}{100}) + 2 \times (\frac{1}{1000})$
- (D) $1 \times 10 + 9 \times 1 + 6 \times (\frac{1}{10}) + 2 \times (\frac{1}{100}) + 8 \times (\frac{1}{1000})$

4. A restaurant owner orders 32 boxes of napkins. If there are 250 napkins in each box, how many napkins are in the whole order?

- (F) 6,000 napkins
- (G) 7,000 napkins
- (H) 7,900 napkins
- (J) 8,000 napkins

5. The number of eggs a farm sells to supermarkets each year is represented by the expression below. Which value is equivalent to the expression?

$$2.6 \times 10^5$$

- (A) 26,000,000
- (B) 2,600,000
- (C) 260,000
- (D) 26,000

6. Lynn buys 0.375 kilogram of turkey. She also buys ham. If the ham weighs more than the turkey, which could be the weight of the ham?

$$0.375 \text{ kg} < \square$$

- (F) 0.325 kg
- (G) 0.3 kg
- (H) 0.37 kg
- (J) 0.39 kg



MATHEMATICS**● Part 2: Number and Operations in Base Ten (cont.)****Directions:** Choose the best answer for each question.

7. A furniture store orders 12 of the same chair. If the total order costs \$4,344, what is the cost of each chair?
- (A) \$360
(B) \$362
(C) \$382
(D) \$462
8. The width of a notebook is 12.124 centimeters. What is this width rounded to the nearest hundredth?
- (F) 12.10 cm
(G) 12.13 cm
(H) 12.12 cm
(J) 12.14 cm
9. The number of boats at a boat show is represented by the expression below. Which value is equivalent to the expression?
- 8×10^3
- (A) 80
(B) 800
(C) 8,000
(D) 80,000
10. Peter measures the area of two houses. One house measures 102.25 square meters. If the second house is larger, which could be the area of the second house?
- (F) 102.21 m²
(G) 102.32 m²
(H) 102.23 m²
(J) 102.24 m²
11. The height of a tree is 463.15 centimeters. Which shows 463.15?
- (A) four hundred sixty-three and fifteen hundredths
(B) four hundred sixty and fifteen hundredths
(C) four hundred sixty-three and five thousandths
(D) four hundred sixty-three and five tenths
12. A company made 42,835 computers last year. What is the value of the digit 4?
- (F) 4
(G) 400
(H) 4,000
(J) 40,000



MATHEMATICS**● Part 3: Number and Operations—Fractions****Directions:** Choose the best answer for each question.

1. Alicia buys $\frac{7}{12}$ pound of chicken salad and $\frac{1}{4}$ pound of cheese at a deli. How much more chicken salad than cheese did she buy?
- (A) $\frac{11}{12}$ lb.
 (B) $\frac{3}{4}$ lb.
 (C) $\frac{1}{4}$ lb.
 (D) $\frac{1}{3}$ lb.
2. If 4 meters of tape is evenly divided into 24 pieces, how long is each piece?
- (F) $\frac{1}{8}$ m
 (G) $\frac{1}{6}$ m
 (H) $\frac{1}{4}$ m
 (J) $\frac{1}{3}$ m
3. Joel has $3\frac{3}{4}$ boxes of cereal, and $\frac{1}{4}$ of the cereal is whole grain. How much of the cereal is whole grain?
- (A) $\frac{15}{16}$ box
 (B) $\frac{1}{15}$ box
 (C) $1\frac{1}{4}$ boxes
 (D) $3\frac{1}{2}$ boxes
4. A recipe calls for $1\frac{1}{2}$ cups of oil. Brennan adds another $\frac{1}{6}$ cup of oil to the recipe. How many cups of oil does he use in all?
- (F) $1\frac{2}{3}$ cups
 (G) $1\frac{1}{2}$ cups
 (H) $1\frac{4}{5}$ cups
 (J) $1\frac{5}{6}$ cups
5. If 4 people share $\frac{1}{4}$ pound of walnuts equally, how many pounds will each person get?
- (A) $\frac{1}{16}$ lb.
 (B) $\frac{1}{12}$ lb.
 (C) $\frac{1}{4}$ lb.
 (D) 1 lb.
6. Each day, Nicole rides her bike $\frac{5}{6}$ mile. If she rides her bike for 7 days, how far does she ride in all?

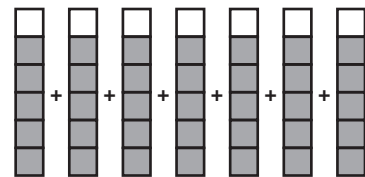

- (F) $5\frac{2}{3}$ miles
 (G) $5\frac{5}{6}$ miles
 (H) $6\frac{1}{6}$ miles
 (J) $7\frac{5}{6}$ miles



MATHEMATICS

● Part 3: Number and Operations—Fractions (cont.)

Directions: Choose the best answer for each question.

7. Nancy makes punch for a party. She combines $\frac{9}{12}$ gallon of cranberry juice with $\frac{5}{12}$ gallon of orange juice. How many gallons of punch does she make in all?

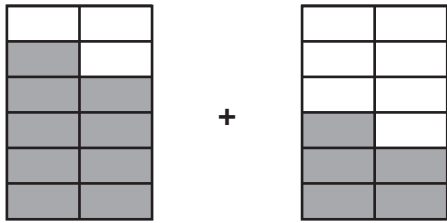

- (A) $\frac{5}{12}$ gallon
 (B) $\frac{7}{12}$ gallon
 (C) $1\frac{2}{3}$ gallons
 (D) $1\frac{1}{6}$ gallons
8. Which statement is true for the product of the expression below?
- $$\frac{1}{2} \times 12 = \square$$
- (F) The product will be less than 12.
 (G) The product will be less than $\frac{1}{2}$.
 (H) The product will be greater than 12.
 (J) The product will be equal to 12.
9. If 4 pizzas are shared equally among 8 people, what is each person's share?

- (A) $\frac{1}{8}$
 (B) $\frac{1}{6}$
 (C) $\frac{1}{4}$
 (D) $\frac{1}{2}$

10. Rafael has a piece of rope that is $\frac{7}{10}$ meter in length. If he cuts off $\frac{2}{5}$ meter, what length of the rope is left?

- (F) $\frac{1}{10}$ m
 (G) $\frac{2}{10}$ m
 (H) $\frac{3}{10}$ m
 (J) $\frac{2}{5}$ m

11. Each serving of steak at a restaurant is $\frac{3}{8}$ pound. If 12 orders are sold, how many pounds of steak are sold?

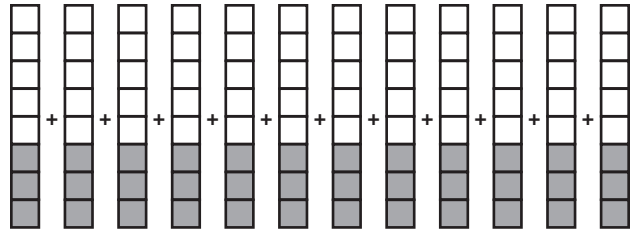

- (A) $3\frac{1}{2}$ lb.
 (B) $4\frac{3}{4}$ lb.
 (C) $4\frac{1}{4}$ lb.
 (D) $4\frac{1}{2}$ lb.
12. $\frac{11}{12} - \frac{3}{4} = \square$

- (F) $\frac{1}{12}$
 (G) $\frac{1}{3}$
 (H) $\frac{1}{4}$
 (J) $\frac{1}{6}$



MATHEMATICS**● Part 3: Number and Operations—Fractions (cont.)****Directions:** Choose the best answer for each question.

13. What is the area of a rectangle with sides $5\frac{1}{4}$ inches and $9\frac{3}{4}$ inches?

(A) $45\frac{3}{16}$ in²
(B) 30 in²
(C) $51\frac{3}{16}$ in²
(D) $37\frac{9}{16}$ in²

14. Rob lives $\frac{7}{8}$ mile from school. He has walked $\frac{1}{2}$ of the way to school. How far has Rob walked?

(F) 1 mile
(G) $\frac{7}{16}$ mile
(H) $\frac{14}{5}$ mile
(J) $\frac{2}{15}$ mile

15. A pie has been partially eaten so that only $\frac{1}{3}$ remains. There are 5 people who want to share the amount that is left. What fraction of the original pie will each get if they share what is left equally?

(A) $\frac{1}{5}$
(B) $\frac{1}{15}$
(C) $\frac{1}{8}$
(D) $\frac{1}{12}$

16. A carpenter is building a bookshelf and needs 3 pieces of wood that are each $18\frac{7}{8}$ inches long. At least how long must a single board be to be cut into those 3 pieces?

$$18\frac{7}{8} \times 3 = \square$$

(F) $54\frac{7}{8}$ in.
(G) $56\frac{5}{8}$ in.
(H) $55\frac{7}{8}$ in.
(J) $55\frac{5}{8}$ in.

17. Jerome has baked 18 cookies for his friends, but all of the cookies are big. He decides to cut each cookie evenly into fourths. How many cookie pieces does Jerome have?

(A) 22
(B) 72
(C) 54
(D) 36

18. Which correctly describes the size of the missing factor?

$$\frac{1}{2} \times \square = 14$$

(F) less than $\frac{1}{2}$
(G) less than 1
(H) greater than 14
(J) greater than 34



MATHEMATICS

● Part 4: Measurement and Data

Directions: Choose the best answer for each question.

1. Carl's dining room table measures 30 inches tall. How many feet tall is the table?

- (A) 2 feet, 4 inches
- (B) 2 feet, 5 inches
- (C) 2 feet, 6 inches
- (D) 2 feet, 8 inches

2. In the figure below, each cube represents a cubic inch. What is the volume of the figure?

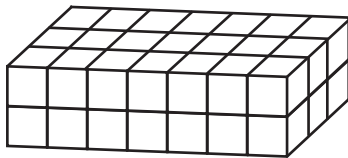

- (F) 32 cubic inches
- (G) 38 cubic inches
- (H) 40 cubic inches
- (J) 42 cubic inches

3. What is the volume of the figure in cubic units?

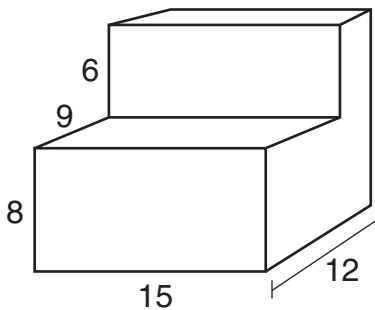

- (A) 1,080 cubic units
- (B) 1,584 cubic units
- (C) 2,520 cubic units
- (D) 1,710 cubic units

4. Mr. Andres has pieces of string that are each $1\frac{1}{4}$, $1\frac{1}{2}$, or $1\frac{3}{4}$ feet long. The line plot below shows how many pieces of each length he has. How many feet of string does he have all together?

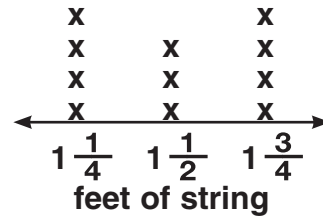

- (F) $9\frac{1}{2}$ ft.
- (G) $11\frac{1}{2}$ ft.
- (H) $15\frac{3}{4}$ ft.
- (J) $16\frac{1}{2}$ ft.

5. The figure below represents the dimensions of Ariel's house in meters. What is the volume of the house?

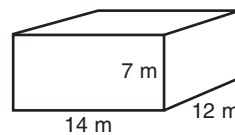

- (A) 726 m²
- (B) 776 m³
- (C) 1,176 m²
- (D) 1,176 m³

6. In the figure below, each cube represents a cubic centimeter. What is the volume of the figure?

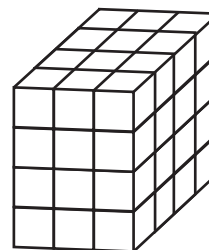

- (F) 24 cm³
- (G) 36 cm³
- (H) 48 cm³
- (J) 60 cm³



MATHEMATICS

● Part 4: Measurement and Data (cont.)

Directions: Choose the best answer for each question.

7. A screw is 15 centimeters long. What is its length in meters?

- (A) 0.0015 m
- (B) 0.015 m
- (C) 1.5 m
- (D) 0.15 m

8. For a science experiment, Chase fills containers with $\frac{1}{4}$, $\frac{1}{2}$, or $\frac{3}{4}$ cup of pond water. The line plot below shows how many containers have each amount of water. If he decides to spread out the water evenly among the containers, how many cups of water will be in each container?

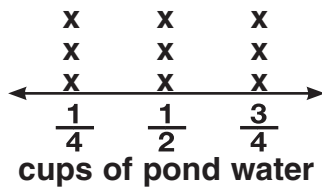

- (F) $\frac{1}{2}$ cup
- (G) $\frac{3}{4}$ cup
- (H) $\frac{1}{4}$ cup
- (J) $\frac{1}{3}$ cup

9. What is the volume of the container?

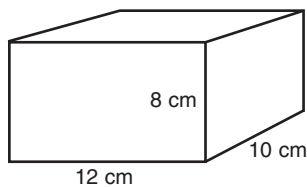

- (A) 860 cm³
- (B) 900 cm³
- (C) 960 cm³
- (D) 1,152 cm³

10. The market is 3.8 kilometers from Kara's house. What is this distance in meters?

- (F) 0.0038 m
- (G) 0.038 m
- (H) 380 m
- (J) 3,800 m

11. What is the volume of the container?

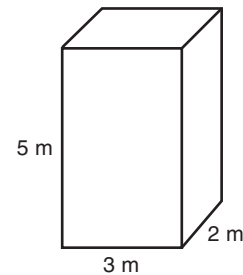

- (A) 25 m³
- (B) 28 m³
- (C) 30 m³
- (D) 36 m³

12. What is the volume of the figure in cubic units?

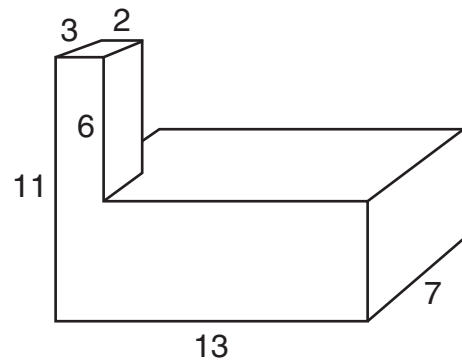

- (F) 491 cubic units
- (G) 455 cubic units
- (H) 965 cubic units
- (J) 1,001 cubic units



MATHEMATICS**● Part 5: Geometry****Directions:** Choose the best answer for each question.

1. What are the coordinates of point
- D*
- ?

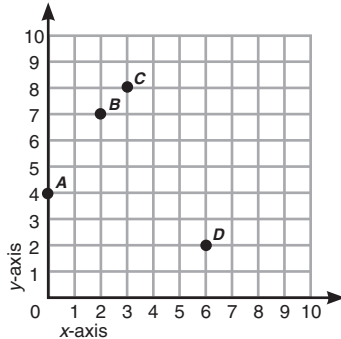

- (A) (2, 6)
 (B) (2, 7)
 (C) (7, 2)
 (D) (6, 2)

2. Which statement best describes a rhombus?

- (F) It has 4 congruent sides.
 (G) It has 4 parallel sides.
 (H) It has 4 right angles.
 (J) It has 2 right angles.

3. Which makes the statement true?

A rectangle is sometimes, but not always, a _____.

- (A) parallelogram
 (B) trapezoid
 (C) quadrilateral
 (D) square

4. Which point represents (4, 5)?

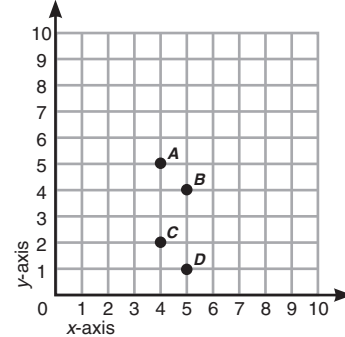

- (F) point A
 (G) point B
 (H) point C
 (J) point D

5. Use the graph above. What are the coordinates of point
- B*
- ?

- (A) (4, 5)
 (B) (5, 4)
 (C) (5, 1)
 (D) (4, 2)

6. Which statement is not true for all rectangles?

- (F) They have 4 right angles.
 (G) They have 2 pairs of congruent sides.
 (H) They have 2 pairs of parallel sides.
 (J) They have 4 congruent sides.

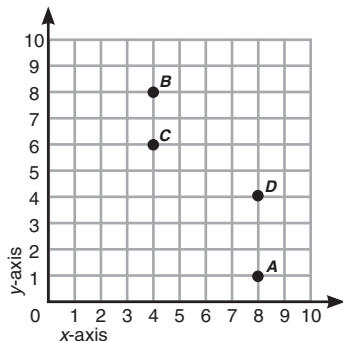

MATHEMATICS**● Part 5: Geometry (cont.)****Directions:** Choose the best answer for each question.**7. What are the coordinates of point *D*?**

- (A) (4, 6)
 (B) (4, 8)
 (C) (8, 1)
 (D) (8, 4)

8. Which shape is also a quadrilateral?

- (F) triangle
 (G) circle
 (H) rhombus
 (J) pentagon

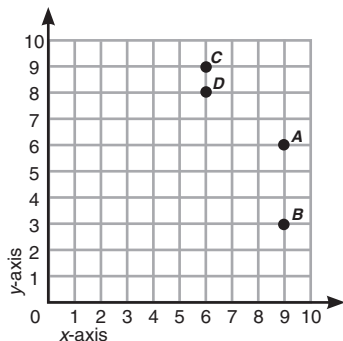
9. Which point represents (6, 9)?

- (A) point A
 (B) point B
 (C) point C
 (D) point D

10. Which statement best describes a trapezoid?

- (F) A trapezoid has 2 pairs of parallel sides.
 (G) A trapezoid has 1 pair of parallel sides.
 (H) A trapezoid has 4 congruent sides.
 (J) A trapezoid has 4 congruent angles.

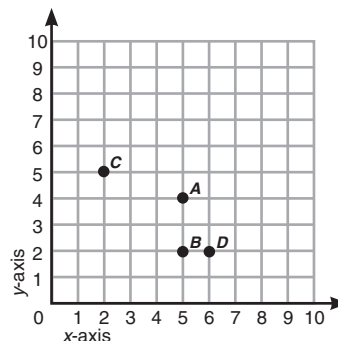
11. Which point represents (5, 2)?

- (A) point A
 (B) point B
 (C) point C
 (D) point D

12. Which statement is true for all parallelograms?

- (F) They have 4 congruent sides.
 (G) They have 4 right angles.
 (H) They have 4 sides.
 (J) They have 4 congruent angles.



ANSWER KEY

English Language Arts

Part 1: Reading Literature

• Page 2

1. C
2. G

• Page 3

3. D
4. G
5. C
6. F
7. B
8. F

• Page 4

9. C
10. F
11. B
12. J
13. B
14. H

Part 2: Reading Informational Text

• Page 6

1. C
2. F
3. B
4. G

• Page 7

5. C
6. J
7. D
8. G
9. B
10. H

• Page 8

11. A
12. H
13. A
14. H
15. A
16. G

Part 4: Language

• Page 10

1. C
2. J
3. C
4. H
5. A
6. G

• Page 11

7. A
8. G
9. D
10. F
11. A
12. G

• Page 12

13. C
14. H

15. D

16. H

17. C

18. G

• Page 13

19. A

20. H

21. D

22. H

23. D

24. F

Mathematics

Part 1: Operations and Algebraic

Thinking

• Page 14

1. C

2. F

3. B

4. J

5. B

6. J

• Page 15

7. D

8. H

9. A

10. F

11. D

12. H

Part 2: Number and Operations in

Base Ten

• Page 16

1. C

2. F

3. D

4. J

5. C

6. J

• Page 17

7. B

8. H

9. C

10. G

11. A

12. J

Part 3: Number and Operations—

Fractions

• Page 18

1. D

2. G

3. A

4. F

5. A

6. G

• Page 19

7. D

8. F

9. D

10. H

11. D

12. J

• Page 20

13. C

14. G

15. B

16. G

17. B

18. H

Part 4: Measurement and Data

• Page 21

1. C

2. J

3. D

4. J

5. D

6. H

• Page 22

7. D

8. F

9. C

10. J

11. C

12. F

Part 5: Geometry

• Page 23

1. D

2. F

3. D

4. F

5. B

6. J

• Page 24

7. D

8. H

9. C

10. G

11. B

12. H